

## EK-3020 Temperature Controller User Manual

### General

This controller is suitable for temperature control of the middle and low temperature cold storage. It could measure, display and control temperature, with the function of temperature calibration, forced defrost and temperature over temperature alarm and sensor failure alarm, one key recovery of the factory default value, parameters preset and one key recovery. It adopts touch key design with the key lock function.

One way sensor input: cabinet temperature sensor(Pb1) .

Two way control output: Refrigeration and defrost.

### Features

- ◆ Six touch key design, quick parameter setting, easy operation.
- ◆ Multiple defrost control modes, more stable and energy saving.
- ◆ Defrost cycle power off memory function.
- ◆ Construction contractor could preset a group of parameters, with one key recovery function.

### Technical parameters

- 1) Measuring range: -40 C ~ 99 C
  - 2) Controlling range: -40 C ~ 85 C ;
  - 3) Accuracy: -30 C ~ 50 C , ±1 C ±0.5dig; others, ±2 C ±0.5dig
  - 4) Resolution: 0.1 C / 1 C
  - 5) Mounting size: 71mm\*29mm
  - 6) Power supply: 220VAC±10%, 50/60Hz
  - 7) Power consumption: <5W
  - 8) Output capacity:
    - Refrigeration: 10A/220VAC (or 16A/220VAC directly drive a single phase compressor 1HP)
    - Defrost: 10A/220VAC
  - One way buzzer alarm output
  - 9) Work ambient temperature: -5 C ~ 60 C ; work ambient humidity: 10% ~ 90% non condensing
  - 10) Storage temperature: -25 C ~ 75 C
  - 11) Sensor type: NTC (10KΩ/25 C , B value 3435K)
  - 12) Sensor length: 2M
1. Operation and display panel



Display panel can display three digits, one status indicator ( key lock ) , four parameters descriptors ( On temp , Off temp , Def time , Def cycle ) .

Under normal running status, all descriptors will not light; when enter the menu setting mode, the corresponding parameter descriptor lights. Under normal running status, if there is refrigeration output, "On" descriptor lights; if defrost runs, "Def" descriptor lights.

#### 2. Indicator light status description

Indicator light	Symbol	Status	Meaning
Key lock		OFF	Unlocked status
		ON	Key locked status
Refrigeration	On	ON	Refrigeration work
		OFF	Refrigeration stop
		FLASH	Refrigeration time delay
Defrost	Def	OFF	Defrost stop
		Flash(slowly)	Defrost delay
		Flash(quickly)	Defrost dripping
		On	Defrost work

### 3. Key description

There are in total six keys in the controller:

- : forced defrost key;      "On Temp";      " Off Temp";
- : UP key;      : DOWN key;      unlock/OK key;

#### Operation instruction:

##### 1. Controller locking and unlocking

Under the status of controller locking, press for one second, the controller will be unlocked, and at the same time, the buzzer beeps for about 0.5second. If no key operation within 30seconds, the controller will lock automatically.

##### 2. User menu setting

Under the normal running status, press "On Temp" ( or "Off Temp" ) , the corresponding parameter descriptor lights, and it displays the value of "On Temp" ( or "Off Temp" ) in the display window, which indicating that it has entered to the setup menu of "On Temp" ( or "Off Temp" ). The parameters could be adjusted by pressing the keys "or" , and if the keys "or" "is kept pressed, the parameters could be adjusted quickly. In the setting mode, press and release the key or no key operation within 30 seconds, it will exit from setting mode and save the parameters.

Parameter descriptor	Description	Setting range	Default setting	Work mode	Note
<b>On Temp</b> Descriptor lights	Compressor start temperature	Off Temp ~ +85.0 C	10.0 C	Refrigeration	If cabinet temperature is higher than set temperature, refrigeration starts.
<b>Off Temp</b> Descriptor lights	Compressor shutdown temperature	-40.0 C ~ Temp On	-10.0 C	Refrigeration	If cabinet temperature is lower than set temperature, refrigeration closes.

##### 3. System menu setting

Under the normal running status, press for more than 5seconds, and it will display parameter code "F1" in the temperature display window , which indicating that it has entered to the system setup menu. The parameter codes could be switched by pressing the keys "or" , and press and release to display the corresponding parameter values. The parameter could be adjusted by pressing the keys "or" , and if the keys "or" "is kept pressed, the parameters could be adjusted quickly. Press and release the key to save the modified parameter value and return to display parameter code.

In System menu setting status, press the key for 5seconds or no key operation within 30seconds, it will save the parameters and exit from system menu setting status. If an error occurs when you save the parameters, it shows "Err" in the temperature display window, and it returns to the normal display status in 5 seconds.

In System setting status, press and hold " "key for more than 5 seconds, it will blinkingly display

password setting. The hide menu is unavailable to access until a correct password is set. The password fixed value is " -15 ". Under System menu, press  key for 5 seconds, or no key operation within 30 seconds, it will exit from system setting menu, and it will save the parameters .

Parameters	Description	Setting range	Default value	Note
F1	Defrost time	1~120 Min	30 Min	Duration time during defrost
F2	Defrost cycle	0~120 Hour	6 Hour	The interval during two defrosts (Auto record every one hour)
F3	Defrost cycle calculation	0: Cumulative controller work time after power on 1: Cumulative compressor work time after power on	1	
F4	Dripping time after defrost	0~120min	3min	Time delay after finishing defrost
F5	Defrost type	0: Electric heating defrost 1: Hot gas defrost	0	Before hot gas defrost, the compressor stops for 3minutes then start defrost, to make sure the reliability of the system. After hot gas defrost, compressor starts after 2 minutes time delay.
F9	Compressor start time delay	0~10Min	0	Compress start minimum time interval from its last stop (include the compressor start time delay for the initial power on)
F10	Over temperature alarm time delay after power on	0~24.0Hour	2.0Hour	After power on, during this time range, there is no over temperature alarm signal
F11	Over temperature alarm	0~50.0℃	5.0℃	If cabinet temperature is higher than "On Temp value + Over temperature alarm value" or lower than "Off Temp value-over temperature alarm value", it alarms.
F12	Over temperature alarm time delay	0~120Min	10Min	Alarm won't occur until over temperature duration is longer than this parameter.
F13	Temperature calibration of cabinet sensor	-10.0℃~+10.0℃	0.0℃	When the measured cabinet temperature has an error, temperature could be calibrated by this parameter.

Hide Menu:				
H1	Compressor stop time in the mode of "Run/stop in a proportional time"	1~60Min	30Min	Compressor stop time during when cabinet sensor fails.
H2	Compressor start time in the mode of "Run/stop in a proportional time"	0~60Min	15Min	Compressor start time during when cabinet sensor fails.
H3	Cabinet temperature upper limit alarm value	Cabinet temperature lower limit alarm value~85.0℃	20.0℃	Note: If H5=1, this parameter item will be disabled.
H4	Cabinet temperature lower limit alarm value	-40.0℃~Cabinet temperature upper lower limit alarm value	-20.0℃	Note: If H5=1, this parameter item will be disabled.
H5	Over temperature alarm mode	0: Absolute temperature 1:Temp On/Off value ± Over temperature alarm value	1	
H6	Start buzzer alarm	0: No 1: Yes	1	Buzzer beeps or not during alarm
H7	Display mode during defrost and dripping	0:Normal cabinet temperature 1:Display dEF 2: Display start-defrost cabinet temperature	0	Note: If the cabinet temperature reaches start-defrost-temperature within 15minutes after defrost dripping, it displays real-time cabinet temperature.
H17	Switch between Integer and decimal	0: Decimal 1: Integer	0	

#### 5. Manual defrost



In the status of non-defrosting , non-defrost-dripping, non-parameter setting , and defrost cycle is not set to 0 , press  key for more than three seconds, it enters to manual defrost status, and the defrost working indicator lights and start defrosting.

In the defrost status (non-parameter setting status), press  key for more than three seconds, it exits from defrost status, and the defrost working indicator flashes, defrost stops and start defrost dripping.

#### 6. Buzzer alarm mute

Press any key to eliminate the alarm buzzer beeping , but the alarm indicator light will not be off until the alarm is released.

#### 7. One key recovery of factory parameters

In the key lock status, press the "" key for more than 10 seconds, then display "rES" for 3 seconds , within these three seconds, press  key to recover the parameters to the factory default values, and it displays "YES". If an error occurs during the parameters saving, display "Err" in the temperature display window, and in 3 seconds, it is in the normal display. It is recommended at this time to re-energize the controller.

#### 8. Parameter preset and one key recovery

In the key lock status, press "On Temp" key for more than 10 seconds, it displays "COP" for 3 seconds,

within these three seconds, press **OK** key to copy the current parameter setting as the factory preset data, and it displays "YES", so that end-users could recover the controller parameters to the appropriate setting in case of emergency.

In the key lock status, press "Off Temp" key for more than 10 seconds, it displays "don" for 3 seconds, within these three seconds, press **OK** key to recover to the factory preset parameter setting and it displays "YES". It is recommended at this time to re-energize the controller.

Note 1: Before recovering to factory preset parameter setting, to make sure that the parameters have previously backed up. Otherwise, it will recover to the factory default parameters.

### Control output

#### 1) Refrigeration control:

Normal status: When the cabinet temperature is higher than "On Temp" value, compressor starts; when the cabinet temperature is lower than "Off Temp" value, compressor stops.

Compressor startup condition (meet all the condition as below):

- Compressor stop time exceeds the set compressor time delay;
- When cabinet temperature  $\geq$  "On Temp" value or during hot gas defrost (In non-defrost and non-defrost-dripping status).

Compressor close condition (meet any of the conditions as below):

- Cabinet temperature  $\leq$  "Off Temp" value;
- When start electric-heating defrost;
- When hot gas defrost stops;

#### 2) Defrost control

Defrost startup condition (meet all the condition as below):

- Defrost cycle is not set as 0;
- Finish the set "defrost cycle", or forced defrost starts.

Defrost close condition: It is controlled by defrost time. After start defrosting, If defrost time is too long and exceeds "defrost time", the controller will stop defrost. It could exit from defrost status through manually pressing the key of "forced defrost"  for three seconds.

Defrost dripping time: The purpose of defrost dripping is to discharge the water accumulated during defrost in the evaporator. If the water could not be discharged timely, the water will be frozen again during refrigeration. Therefore, it is necessary to set a defrost dripping time to make sure a timely water discharge during defrost. During this period, the compressor does not start, and "defrost" working status indicator flashes at this time.

#### 3) Alarm output

The controller has one way buzzer alarm output. In the running status, when the following conditions occur, the buzzer beeps:

- When the cabinet sensor fails, it displays the fault code E1 in the temperature display window; the controller will run in the fixed pattern: the compressor stops for 30 minutes, then runs for 15 minutes. After cabinet sensor failure is released, it enters to the normal temperature control mode and exits from the fixed compressor start/stop mode.

- When cabinet temperature  $\geq$  "On Temp value" + "over temperature alarm value" (H5 = 1) and the duration  $\geq$  "temperature alarm time delay" and "Over temperature alarm time delay after power on", high temperature alarm occurs, it alternately displays the current cabinet temperature and the fault code HA in the temperature display window. When cabinet temperature  $<$  "On Temp value" + "over temperature alarm value", high temperature alarm is canceled. When H5=0, it works in the same way.

- When cabinet temperature  $\leq$  "Off Temp value" - "over temperature alarm value" (H5 = 1) and the duration  $\geq$  "temperature alarm time delay" and "Over temperature alarm time delay after power on", low temperature alarm occurs, it alternately displays the current cabinet temperature and the fault code LA in the temperature display window. When cabinet temperature  $>$  "Off Temp value" - "over temperature alarm value", low temperature alarm is canceled. When H5=0, it works in the same way.

### Wiring diagram

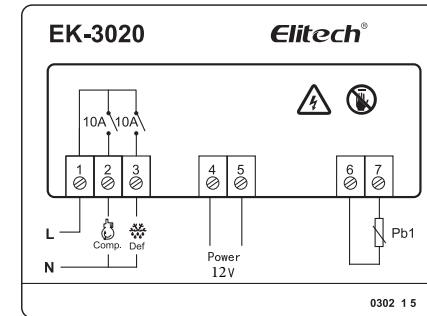

### Safety rules

#### ★Danger:

1. Strictly distinguish the power wire, relay output, sensor down-lead and data line, and the relay could not be overloaded.

2. Prohibit connecting the wire terminals without electricity cut-off.

#### ★Warning:

Prohibit using this unit under the environment of over damp, high temp., strong electromagnetism interference or strong corrosion.

#### ★Notice:

1. The power supply should conform to the voltage value indicated in the instruction, and make sure a steady power supply.

2. To avoid the possible interference, the sensor down-lead/data line and power wire should be kept in a proper distance.

3. When evaporator sensor is installed, the sensor should be well connected with the copper tube which is 5cm away from evaporator inlet.